

POLARIZING MICROSCOPY FOR EXAMINING MECHANISMS OF THE DECOMPOSITION OF  
SINGLE CRYSTAL MATERIALS

Haruhiko TANAKA and Nobuyoshi KOGA

Chemistry Laboratory, Faculty of School Education, Hiroshima University,  
Shinonome, Minami-ku, Hiroshima, 734(Japan)

ABSTRACT

Either  $R_{1,24}$  or  $A_{2,80}$  law was estimated as appropriate for the isothermal dehydration of single crystalline  $\text{CuSO}_4 \cdot 5\text{H}_2\text{O}$ , by analyzing mass-change traces at various temperatures. Microscopic examination of thin sections of single crystalline  $\text{CuSO}_4 \cdot 5\text{H}_2\text{O}$  dehydrated partly, under polarized light, revealed that the dehydration proceeds, on the whole, according to one-dimensional phase boundary controlled reaction mechanism,  $R_1$ . It was proposed that the microscopic observation technique can be used effectively to enable students to recognize the complex feature of solid-state reactions.

INTRODUCTION

It seems that many studies so far published on the kinetics and mechanisms of the thermal decompositions of solids lack adequate supporting observations from complementary studies[1]. Besides the conventional kinetic analysis using thermoanalytical instruments, direct observation of the material by microscopy is, for example, very important in determining kinetics and mechanisms of solid-state reactions[2,3]. Optical[2] and electron scanning microscopy[3] played decisive roles in the kinetic studies of solid-state decompositions.

Lately we have shown that observation of thin sections of single crystals decomposed partly, under polarizing light, is also valuable in studying the decomposition mechanism of single crystals[1,4,5]. For the thermal dehydration of single crystalline sodium citrate dihydrate (SCD), it proved that an Avrami-Erofeyev law,  $A_4$ , combined with a phase-boundary controlled reaction,  $R_n$ , regulates the dehydration reaction. Figure 1 shows one of polarizing microscopic views of the internal face (100) of a single crystal of SCD dehydrated partly. On the other hand, crystalline powders (100-170 mesh sieve fraction) of SCD were described by a random nucleation law  $A_1$ , according to the conventional kinetic analysis. We have recognized from such a study that (1) the mechanism, more or

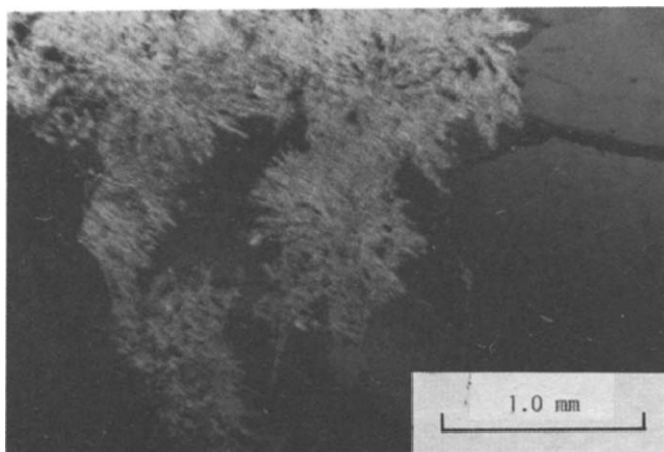
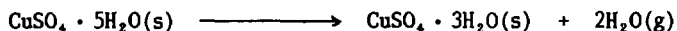

Fig. 1. Polarizing microscopic view of the (100) face of a thin section of the partly dehydrated single crystalline SCD.

less, changes as the reaction proceeds, (2) application of a single model throughout the whole course of a reaction is unlikely, and (3) marked differences are possible in the behavior of single crystals and powders of the same material [1,6].

It seems that the polarizing microscopic technique above is useful for stimulating students' interest and for letting them recognize the complex feature of solid-state reactions[7]. In view of this, it is worth studying kinetics and mechanisms of the dehydration of inorganic solid hydrates, and using the result to help students visualize kinetics and mechanisms of solid state reactions. In the present study, single crystals of  $\text{CuSO}_4 \cdot 5\text{H}_2\text{O}$  were chosen, because this material has often been used in the kinetic investigations. It loses the water of crystallization partially in flowing  $\text{N}_2$  at around  $60^\circ\text{C}$  as follows:



#### EXPERIMENTAL

Single crystals of  $\text{CuSO}_4 \cdot 5\text{H}_2\text{O}$  were grown from the slightly supersaturated aqueous solution at room temperature. The pentahydrate was characterized by determining optical bearings as well as by means of TG and IR spectroscopy.

About 15.0 mg of the single crystal of  $\text{CuSO}_4 \cdot 5\text{H}_2\text{O}$  were loaded onto a platinum pan of 5 mm diameter and 2.5 mm in height in a Rigaku Thermoflex TG-DSC 8085E1 system. The mass-change traces for the isothermal dehydration to its

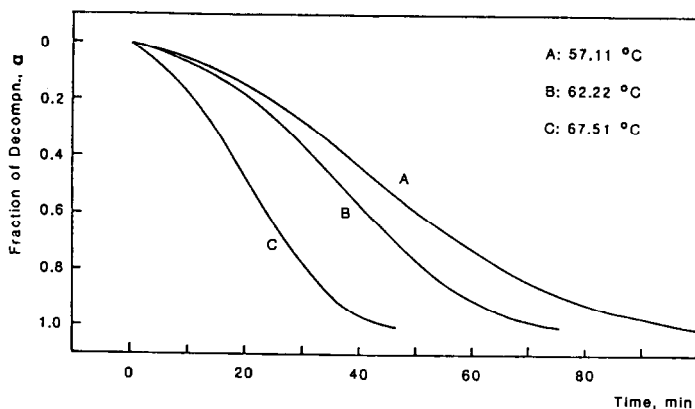

Fig. 2. Typical mass-change traces for the isothermal dehydration of  $\text{CuSO}_4 \cdot 5\text{H}_2\text{O}$  to its trihydrate.

TABLE 1  
Kinetic model functions,  $F(\alpha)$

Model	$F(\alpha)$	Label
Avrami-Erofeyev	$[-\ln(1-\alpha)]^{1/m}$ , $m=1,2,3,4$	$\text{An}$
Contracting geometry	$1-(1-\alpha)^{1/n}$ , $n=1,2,3$	$\text{Rn}$
Prout-Tompkins	$\ln[\alpha/(1-\alpha)]$	$\text{Au}$
One-dimensional diffusion	$\alpha^2$	$\text{D}_1$
Two-dimensional diffusion	$\alpha + (1-\alpha)\ln(1-\alpha)$	$\text{D}_2$
Jander	$[1-(1-\alpha)^{1/3}]^2$	$\text{D}_3$
Ginstling-Broshtein	$1-2\alpha/3-(1-\alpha)^{2/3}$	$\text{D}_4$

trihydrate were recorded at different temperatures in flowing  $\text{N}_2$  at a rate of  $30 \text{ ml min}^{-1}$ . Kinetic analysis was made in the reaction fraction range of 0.1–0.9 throughout.

Thin sections (ca. 0.03 mm thickness) of the single crystals dehydrated partly were prepared as described elsewhere[4,5,7] and observed with a polarizing microscope and photographed.

## RESULTS AND DISCUSSION

Figure 2 shows typical isothermal mass-change traces for the thermal dehydration of single crystalline  $\text{CuSO}_4 \cdot 5\text{H}_2\text{O}$  to its trihydrate. Table 1 lists the kinetic model functions,  $F(\alpha)$ , examined in the present study. Figure 3 shows typical plots of kinetic model functions  $F(\alpha)$  against the time  $t$ , which had

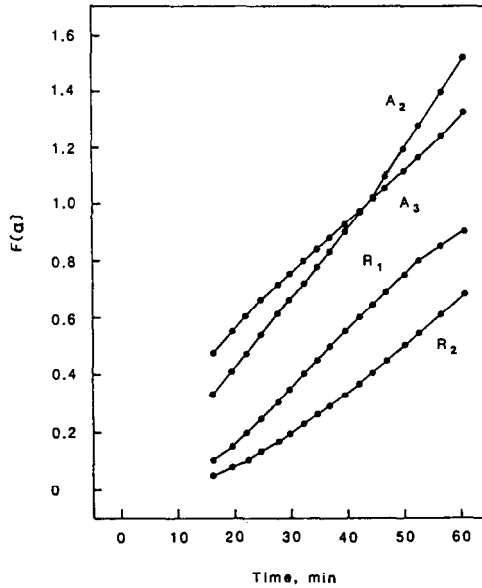

Fig. 3. Typical  $F(\alpha)$  vs.  $t$  plots for the isothermal dehydration of  $\text{CuSO}_4 \cdot 5\text{H}_2\text{O}$  to its trihydrate.

relatively good linearity. In view of the linearity of the plots, either  $R_1$  or  $A_3$  law is selected as a possible  $F(\alpha)$  regulating the dehydration[8]. From computer analysis, an  $R_{1.24}$  or  $A_{2.80}$  law was determined mathematically as the most appropriate  $F(\alpha)$ .

It is interesting to link the result above with observation of thin sections of the single crystal dehydrated partly. Figures 4(a) and (b) show polarizing microscopic views of the (100) face of the single crystalline  $\text{CuSO}_4 \cdot 5\text{H}_2\text{O}$  dehydrated partly. Figure 5 illustrates the crystal habit of  $\text{CuSO}_4 \cdot 5\text{H}_2\text{O}$ . We see from Fig. 4(a) that the reaction is controlled mainly by advancement of the phase boundary and that the growth front has a saw-teeth like structure. We infer from Fig. 4(b) that the product layers were formed by advancing and ceasing alternatively. It follows that the dehydration proceeds, on the whole, according to a law of phase-boundary controlled reaction,  $R_n$ , with a smaller  $n$  value, but not to the alternative,  $A_{2.80}$ . The  $n$  value of 1.24, which theoretically corresponds to an  $R_1$  law, implies that the reaction front tends to advance along the cleavage face  $(\bar{1}\bar{1}0)$ , as is supported by the direct observation above.

We believe that the direct observation of an internal surface enables students to visualize the complex processes of solid-state reactions which are different from homogeneous reactions. One can prepare thin sections of a desired

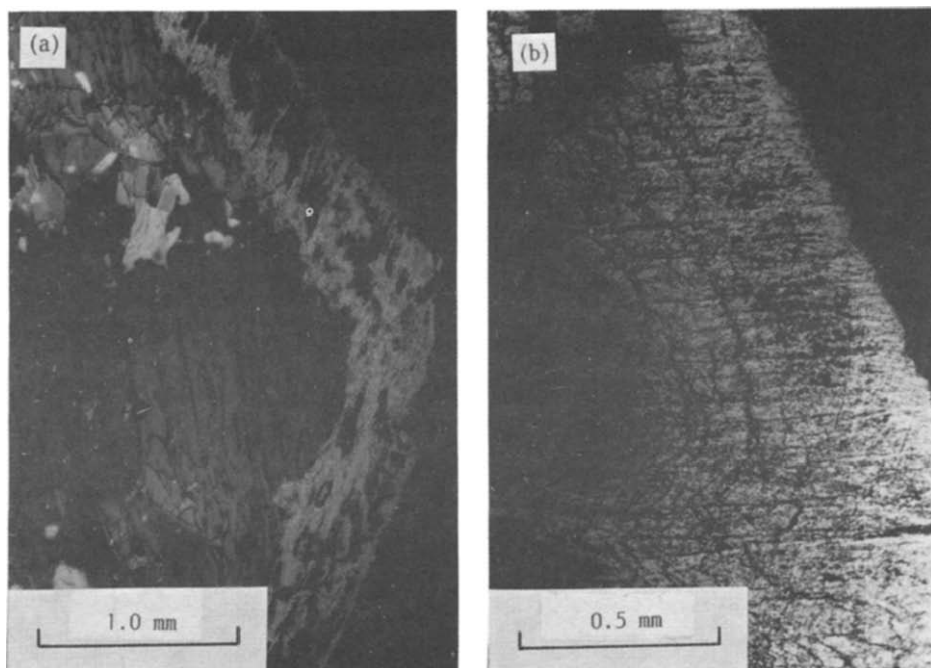

Fig. 4. Typical polarizing microscopic views of the (100) face of thin sections of the partly dehydrated single crystals of  $\text{CuSO}_4 \cdot 5\text{H}_2\text{O}$ .

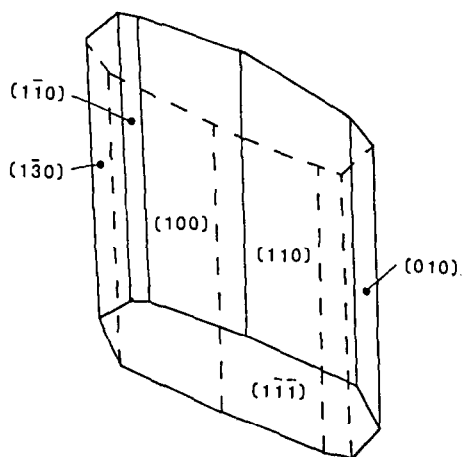

Fig. 5. The crystal habit of  $\text{CuSO}_4 \cdot 5\text{H}_2\text{O}$ .

crystallographic face and preserve it for a long time. A transparency can be used to demonstrate it, when there is not much time to spare. It is evident that the direct observation technique above would be more useful, if it could be linked with conventional kinetic investigations using thermoanalytical equipments[5,7].

#### CONCLUSION

A thermoanalytical kinetic study of the isothermal dehydration of single crystalline  $\text{CuSO}_4 \cdot 5\text{H}_2\text{O}$ , complemented by direct observation of the internal surface of the material dehydrated partly, revealed that the dehydration proceeds, on the whole, according to a law of phase-boundary controlled reaction,  $R_n$ , with  $n=1.24$ . The  $R_{1.24}$  law, which theoretically corresponds to an  $R_1$  law, suggests that the reaction front should advance inwards predominantly along the cleavage face.

It is expected that such a direct observation technique is useful for stimulating students' interest and for helping them recognize the complex feature of solid-state reactions.

#### ACKNOWLEDGMENT

The authors wish to thank Professor G. Yoshino and Mr. T. Hayashi for their help in observing thin sections in polarized light and taking the photographs.

#### REFERENCES

- 1 M.E. Brown, *Thermochim. Acta*, 110(1987)153.
- 2 G.G.T. Guarini and S. Piccini, *J. Chem. Soc., Faraday Trans.1*, 84(1988)331.
- 3 A.K. Galwey, in B. Miller(ed.), *Thermal Analysis, Proc. 7th ICTA*, Kingston, 1982, Wiley Heydon, Chichester, 1982, p.38.
- 4 H. Tanaka and K. Kawabata, *Thermochim. Acta*, 92(1985)219.
- 5 H. Tanaka, Y. Yabuta and N. Koga, *React. Solids*, 2(1986)169.
- 6 J.H. Flynn, M. Brown, and J. Sestak, *Thermochim. Acta*, 110(1987)101.
- 7 H. Tanaka, N. Koga, T. Hayashi and N. Nishimoto, *Kagakutokyoiku*(in Japanese), in press.
- 8 H. Tanaka, S. Ohsima, S. Ichiba and H. Negita, *Thermochim. Acta*, 48(1981)137.